



# Series S

Medium/High Capacity Toggle Switches

## GENERAL SPECIFICATIONS FOR S301 ~ S339

### Electrical Capacity (Resistive & Inductive Load)

**Power Level:** Shown in the following tables















### Other Ratings

**Contact Resistance:** 10 milliohms maximum  
**Insulation Resistance:** 1,000 megohms minimum @ 500V DC  
**Dielectric Strength:** 2,000V AC minimum  
**Mechanical Life:** 30,000 operations minimum for S5AW, S8AW, S9AW, S25AW, S28AW, S29AW  
 50,000 operations minimum for all other models  
**Electrical Life:** 15,000 operations minimum for S331s; 25,000 operations minimum for all others  
**Angle of Throw ( $\alpha$ ):** Shown on following tables

### Materials & Finishes

**Toggle:** Polyamide for flatted lever; brass with chrome plating for all others  
**Bushing:** Brass with chrome plating  
**Case:** Melamine phenol for S300s; phenolic resin for S330s  
**Case Cover:** Steel with zinc plating  
**Movable Contactor:** Copper with silver plating  
**Movable & Stationary Contacts:** Silver alloy capped on copper with silver plating  
**Terminals:** Brass with silver plating

## SINGLE POLE WITH SOLDER LUG

Model	Approvals	Pole & Throw	Toggle Position/Connected Terminals						Electrical Capacity				Angle of Throw
			Down 	Center 	Up 	Resistive			Inductive				
						AC 125V	AC 250V	DC 30V	AC 125V PF 0.6				
S301	 	SPST	ON	1-3	NONE	OFF	—	15A	6A	20A	10A	32°	
S302	 	SPDT	ON	2-3	NONE	ON	2-1	15A	6A	20A	10A	32°	
S303	 	SPDT	ON	2-3	OFF	ON	2-1	15A	6A	20A	10A	32°	
S305	 	SPDT	ON	2-3	NONE	MOM	2-1	15A	6A	20A	8A	32°	
S308	 	SPDT	MOM	2-3	OFF	MOM	2-1	15A	6A	20A	8A	32°	
S309	 	SPDT	ON	2-3	OFF	MOM	2-1	15A	6A	20A	8A	32°	

**Throw & Schematics:**

SPST



SPDT



Note: Terminal numbers are on the switch.

- Standard Hardware: AT503 Face Hex Nut, AT506 Locking Ring, AT508 Lockwasher, AT527M Backup Hex Nut. See [Accessories & Hardware Index](#) for details.
- Solder lug terminal hole accommodates one 10-gauge solid or stranded wire.



S301

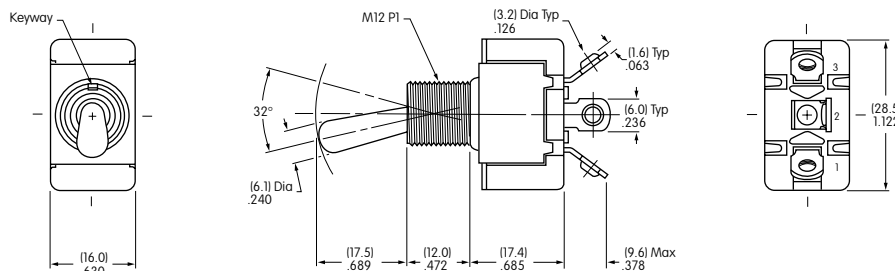

Max. Panel Thickness  
4.7mm (.185")

S301 model does not have terminal 2.



# Series S

## Medium/High Capacity Toggle Switches

### DOUBLE POLE WITH SOLDER LUG

Model	Approvals	Pole & Throw	Toggle Position/Connected Terminals						Electrical Capacity				α = Angle of Throw
			Down 	Center 	Up 		Resistive			Inductive			
							AC 125V	AC 250V	DC 30V	AC 125V PF 0.6			
S331		DPST	ON	1-3 4-6	NONE	OFF	—	25A	25A	25A	10A	25°	
S332		DPDT	ON	2-3 5-6	NONE	ON	2-1 5-4	25A	15A	25A	10A	25°	
S333		DPDT	ON	2-3 5-6	OFF	ON	2-1 5-4	25A	15A	25A	10A	30°	
S335		DPDT	ON	2-3 5-6	NONE	MOM	2-1 5-4	15A	6A	20A	8A	25°	
S338		DPDT	MOM	2-3 5-6	OFF	MOM	2-1 5-4	15A	6A	20A	8A	25°	
S339		DPDT	ON	2-3 5-6	OFF	MOM	2-1 5-4	15A	6A	20A	8A	25°	

**Throw & Schematics:** DPST INTERNAL CONNECTION DPDT Note: Terminal numbers are on the switch.

- Standard Hardware: AT503 Face Hex Nut, AT506 Locking Ring, AT508 Lockwasher, AT527M Backup Hex Nut. See [Accessories & Hardware Index](#) for details.
- Solder lug terminal hole accommodates one 12-gauge solid or stranded wire.

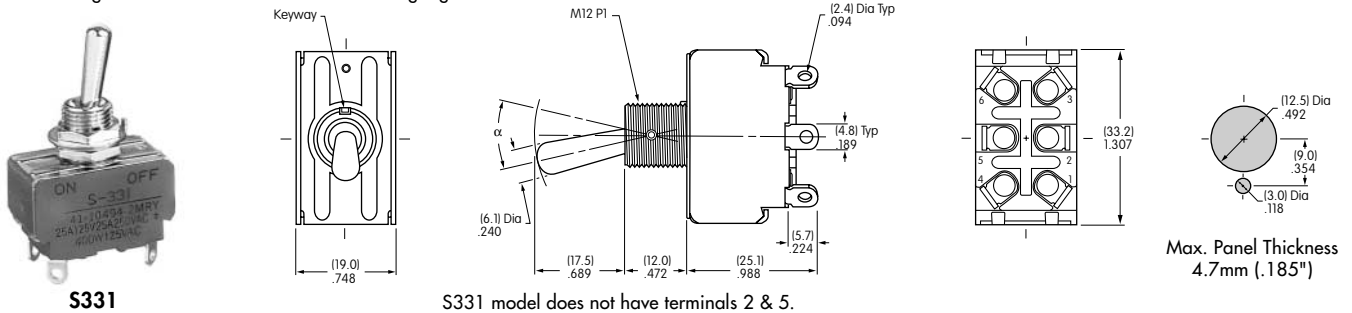

### DOUBLE POLE WITH SOLDER LUG & FLATTED LEVER

Model	Approvals	Pole & Throw	Toggle Position/Connected Terminals						Electrical Capacity				α = Angle of Throw
			Down 	Center 	Up 		Resistive			Inductive			
							AC 125V	AC 250V	DC 30V	AC 125V PF 0.6			
S331R		DPST	ON	1-3 4-6	NONE	OFF	—	25A	25A	25A	10A	25°	
S332R		DPDT	ON	2-3 5-6	NONE	ON	2-1 5-4	25A	15A	25A	10A	25°	
S333R		DPDT	ON	2-3 5-6	OFF	ON	2-1 5-4	25A	15A	25A	10A	30°	
S338R		DPDT	MOM	2-3 5-6	OFF	MOM	2-1 5-4	15A	6A	20A	8A	25°	
S339R		DPDT	ON	2-3 5-6	OFF	MOM	2-1 5-4	15A	6A	20A	8A	25°	

**Throw & Schematics:** DPST INTERNAL CONNECTION DPDT Note: Terminal numbers are on the switch.

- Standard Hardware: AT504M Knurled Nut, AT506 Locking Ring, AT508 Lockwasher, AT527M Backup Hex Nut. See [Accessories & Hardware Index](#) for details.
- Solder Lug terminal hole accommodates one 12-gauge solid or stranded wire.

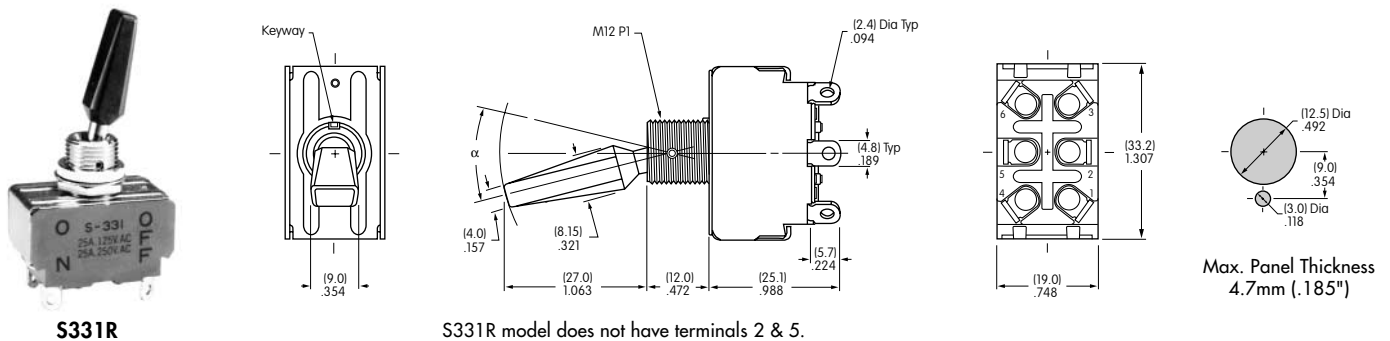

















# Series S

## Medium/High Capacity Toggle Switches

### SINGLE POLE WITH SCREW LUG

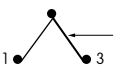
Model	Approvals	Pole & Throw	Toggle Position/Connected Terminals				Electrical Capacity				Angle of Throw
			Down 	Center 	Up 	Resistive			Inductive		
						AC 125V	AC 250V	DC 30V	AC 125V PF 0.6		
S301T	 	SPST	ON 1-3	NONE	OFF —	15A	6A	20A	10A	32°	
S302T	 	SPDT	ON 2-3	NONE	ON 2-1	15A	6A	20A	10A	32°	
S303T	 	SPDT	ON 2-3	OFF	ON 2-1	15A	6A	20A	10A	32°	
S305T	— 	SPDT	ON 2-3	NONE	MOM 2-1	15A	6A	20A	8A	32°	
S308T	— 	SPDT	MOM 2-3	OFF	MOM 2-1	15A	6A	20A	8A	32°	
S309T	— 	SPDT	ON 2-3	OFF	MOM 2-1	15A	6A	20A	8A	32°	

**Throw & Schematics:** SPST  INTERNAL CONNECTION  Note: Terminal numbers are on the switch.

• Standard Mounting Hardware: AT503 Face Hex Nut, AT506 Locking Ring, AT508 Lockwasher, AT527M Backup Hex Nut.





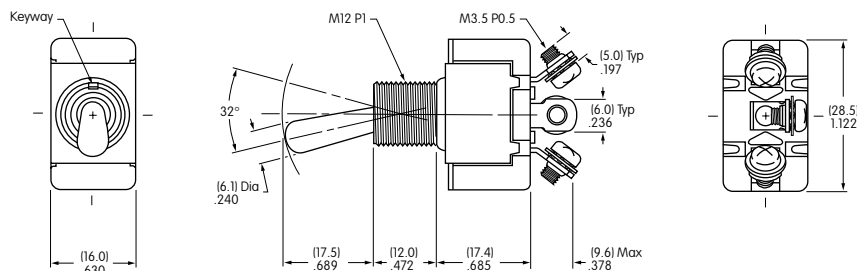





S301T



Max. Panel Thickness 4.7mm (.185")

S301T model does not have terminal 2.

### DOUBLE POLE WITH SCREW LUG

Model	Approvals	Pole & Throw	Toggle Position/Connected Terminals				Electrical Capacity				α = Angle of Throw
			Down 	Center 	Up 	Resistive			Inductive		
						AC 125V	AC 250V	DC 30V	AC 125V PF 0.6		
S331T	 —	DPST	ON 1-3 4-6	NONE	OFF —	15A	15A	15A	10A	25°	
S332T	 —	DPDT	ON 2-3 5-6	NONE	ON 2-1 5-4	15A	15A	15A	10A	25°	
S333T	 —	DPDT	ON 2-3 5-6	OFF	ON 2-1 5-4	15A	15A	15A	10A	30°	
S335T	 —	DPDT	ON 2-3 5-6	NONE	MOM 2-1 5-4	15A	6A	20A	8A	25°	
S338T	 —	DPDT	MOM 2-3 5-6	OFF	MOM 2-1 5-4	15A	6A	20A	8A	25°	
S339T	 —	DPDT	ON 2-3 5-6	OFF	MOM 2-1 5-4	15A	6A	20A	8A	25°	

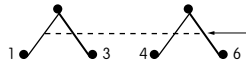
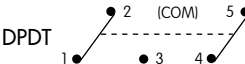
**Throw & Schematics:** DPST  INTERNAL CONNECTION  Note: Terminal numbers are on the switch.

• Standard Mounting Hardware: AT503 Face Hex Nut, AT506 Locking Ring, AT508 Lockwasher, AT527M Backup Hex Nut.



S331T

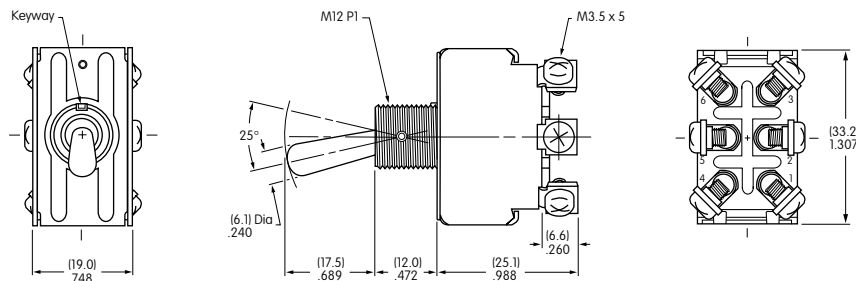

Max. Panel Thickness 4.7mm (.185")

S331T model does not have terminals 2 & 5.



### GENERAL SPECIFICATIONS FOR S31 ~ S49

#### Electrical Capacity (Resistive & Inductive Load)

**Power Level:** Shown in the following tables

#### Other Ratings

**Contact Resistance:** 10 milliohms maximum  
**Insulation Resistance:** 1,000 megohms minimum @ 500V DC  
**Dielectric Strength:** 2,000V AC minimum  
**Mechanical Life:** 50,000 operations minimum  
**Electrical Life:** 25,000 operations minimum  
**Angle of Throw ( $\alpha$ ):** Shown on following tables

#### Materials & Finishes

**Toggle:** PBT resin for flatted lever; brass with chrome plating for all others  
**Bushing:** Brass with chrome plating  
**Case:** Phenolic resin  
**Case Cover:** Steel with zinc plating  
**Movable Contactor:** Copper with silver plating  
**Movable Contacts:** Silver alloy capped on copper with silver plating  
**Stationary Contacts:** Silver alloy capped on copper with silver plating  
**Terminals:** Brass with silver plating

#### Environmental Data

**Operating Temp Range:** -10°C through +70°C (+14°F through +158°F)

#### Installation

**Mounting Torque:** 30 kgf/cm (26 lb/in) for double nut; 15 kgf/cm (13 lb/in) for single nut  
**Maximum Panel Thickness:** Shown beneath panel cutout in switch dimension drawings  
**Soldering Time & Temperature:** 3 seconds @ 350°C or 5 seconds @ 270°C

#### Standards & Certifications

**UL Recognized:** Designated with UL recognized symbol beside part numbers on following pages  
See [Supplement Index](#) to find UL rating details. UL File No. E44145  
Add "/U" to end of part number to order UL mark on switch.

**CSA Certified:** Designated with CSA certified symbol beside part numbers on following pages  
See [Supplement Index](#) to find CSA rating details. File No. LR23535  
Add "/C" to end of part number to order CSA mark on switch.



# Series S

## Medium/High Capacity Toggle Switches

### THREE POLE WITH SOLDER LUG

\*See page Z1 for UL detail.

Model	Approvals	Pole & Throw	Toggle Position/Connected Terminals						Electrical Capacity				α = Angle of Throw
			Down 	Center 	Up 	Resistive			Inductive AC 125V PF 0.6				
						AC 125V	AC 250V	DC 30V					
S31*	—	Ⓢ 3PST	ON	1-3 4-6 7-9	NONE	OFF	—	25A	9A	20A	10A	25°	
S32*	—	Ⓢ 3PDT	ON	2-3 5-6 8-9	NONE	ON	2-1 5-4 8-7	25A	9A	20A	10A	25°	
S33*	—	Ⓢ 3PDT	ON	2-3 5-6 8-9	OFF	ON	2-1 5-4 8-7	25A	9A	20A	10A	30°	
S35	Ⓢ	Ⓢ 3PDT	ON	2-3 5-6 8-9	NONE	MOM	2-1 5-4 8-7	15A	6A	20A	8A	25°	
S38	Ⓢ	Ⓢ 3PDT	MOM	2-3 5-6 8-9	OFF	MOM	2-1 5-4 8-7	15A	6A	15A	8A	25°	
S39	Ⓢ	Ⓢ 3PDT	ON	2-3 5-6 8-9	OFF	MOM	2-1 5-4 8-7	15A	6A	15A	8A	25°	

**Throw & Schematics:** 3PST INTERNAL CONNECTION (COM)

Note: Terminal numbers are on the switch.

- Standard Hardware: AT503 Face Hex Nut, AT506 Locking Ring, AT508 Lockwasher, AT527M Backup Hex Nut. See [Accessories & Hardware Index](#) for details.
- Solder lug terminal hole accommodates one 12-gauge solid or stranded wire.



S32

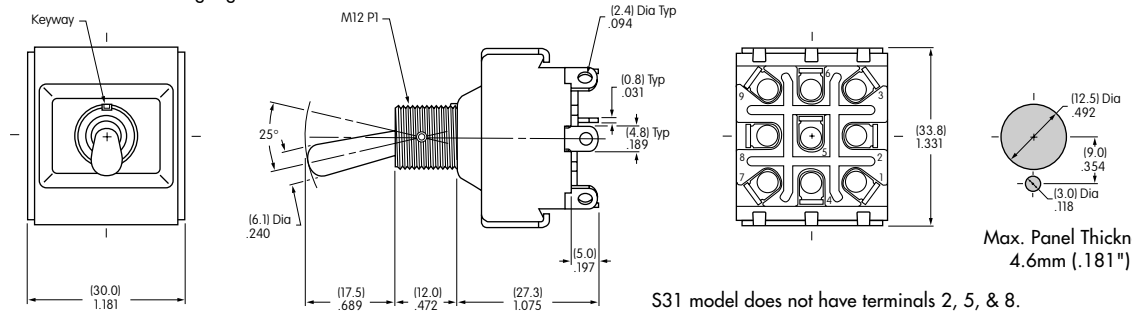

### FOUR POLE WITH SOLDER LUG

\*See page Z1 for UL & CSA details.

Model Suffix R= Flatted Lever	Approvals	Pole & Throw	Toggle Position/Connected Terminals						Electrical Capacity				α = Angle of Throw
			Down 	Center 	Up 	Resistive			Inductive AC 125V PF 0.6				
						AC 125V	AC 250V	DC 30V					
S41/S41R*	—	Ⓢ 4PST	ON	1-3 4-6 7-9 10-12	NONE	OFF	—	25A	9A	20A	10A	25°	
S42/S42R*	—	Ⓢ 4PDT	ON	2-3 5-6 8-9 11-12	NONE	ON	2-1 5-4 8-7 11-10	25A	9A	20A	10A	25°	
S43/S43R*	—	Ⓢ 4PDT	ON	2-3 5-6 8-9 11-12	OFF	ON	2-1 5-4 8-7 11-10	25A	9A	20A	10A	30°	
S45	Ⓢ	— 4PDT	ON	2-3 5-6 8-9 11-12	NONE	MOM	2-1 5-4 8-7 11-10	15A	6A	20A	8A	25°	
S48/S48R	Ⓢ	— 4PDT	MOM	2-3 5-6 8-9 11-12	OFF	MOM	2-1 5-4 8-7 11-10	15A	6A	20A	8A	25°	
S49/S49R	Ⓢ	— 4PDT	ON	2-3 5-6 8-9 11-12	OFF	MOM	2-1 5-4 8-7 11-10	15A	6A	20A	8A	25°	

**Throw & Schematics:** 4PST INTERNAL CONNECTION (COM)

Note: Terminal numbers are on the switch.

- Standard Hardware: AT503 Face Hex Nut, AT506 Locking Ring, AT508 Lockwasher, AT527M Backup Hex Nut. See [Accessories & Hardware Index](#) for details.
- Solder lug terminal hole accommodates one 12-gauge solid or stranded wire.



S42R

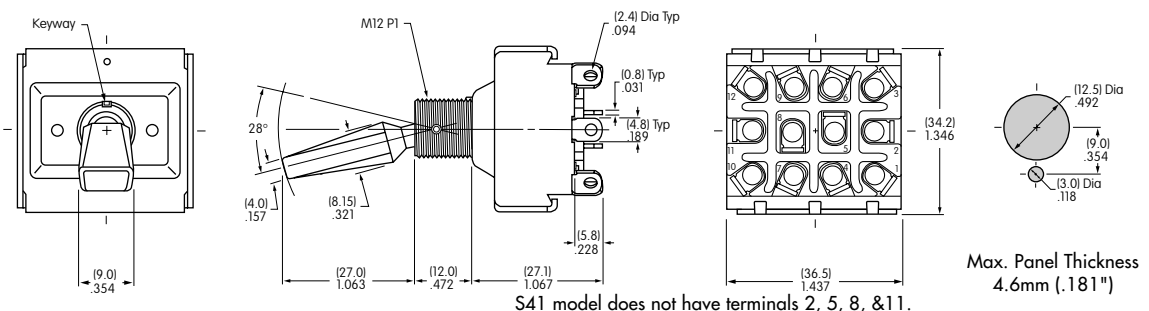



# Series S

## Medium/High Capacity Toggle Switches

### THREE POLE WITH SCREW LUG

*See page Z1 for UL detail.			Toggle Position/Connected Terminals						Electrical Capacity					α = Angle of Throw
Model	Approvals	Pole & Throw	Down	Center	Up	Resistive			Inductive					
						AC 125V	AC 250V	DC 30V	AC125V PF 0.6	AC250V PF 0.6				
S31T*	—	Ⓢ	3PST	ON	1-3 4-6 7-9	NONE	OFF	—	25A	6A	20A	10A	5A	25°
S32T*	—	Ⓢ	3PDT	ON	2-3 5-6 8-9	NONE	ON	2-1 5-4 8-7	25A	6A	20A	10A	5A	25°
S33T*	—	Ⓢ	3PDT	ON	2-3 5-6 8-9	OFF	ON	2-1 5-4 8-7	25A	6A	20A	10A	5A	30°

**Throw & Schematics:**

3PST

INTERNAL CONNECTION

3PDT

INTERNAL CONNECTION

Note: Terminal numbers are on the switch.

• Standard Hardware: AT503 Face Hex Nut, AT506 Locking Ring, AT508 Lockwasher, AT527M Backup Hex Nut. See [Accessories & Hardware Index](#) for details.



S32T

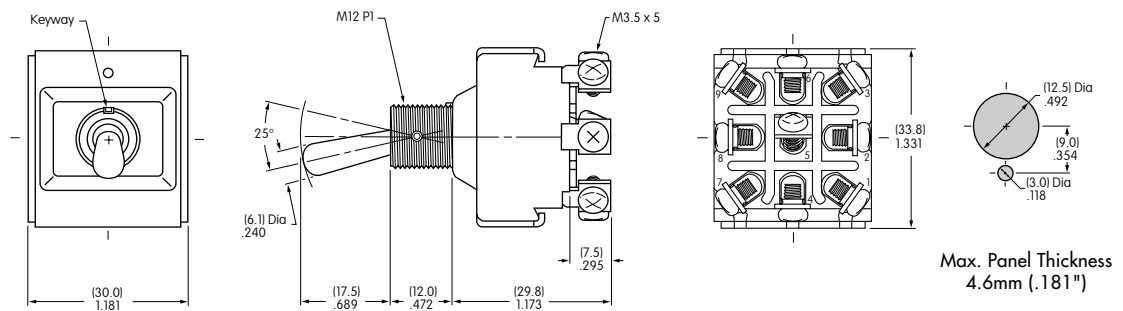

S31T model does not have terminals 2, 5, & 8.

### FOUR POLE WITH SCREW LUG

*See page Z1 for UL detail.			Toggle Position/Connected Terminals						Electrical Capacity					α = Angle of Throw
Model	Approvals	Pole & Throw	Down	Center	Up	Resistive			Inductive					
						AC 125V	AC 250V	DC 30V	AC125V PF 0.6	AC250V PF 0.6				
S41T*	—	Ⓢ	4PST	ON	1-3 4-6 7-9 10-12	NONE	OFF	—	25A	6A	20A	10A	5A	25°
S42T*	—	Ⓢ	4PDT	ON	2-3 5-6 8-9 11-12	NONE	ON	2-1 5-4 8-7 11-10	25A	6A	20A	10A	5A	25°
S43T*	—	Ⓢ	4PDT	ON	2-3 5-6 8-9 11-12	OFF	ON	2-1 5-4 8-7 11-10	25A	6A	20A	10A	5A	30°

**Throw & Schematics:**

4PST

INTERNAL CONNECTION

4PDT

INTERNAL CONNECTION

Note: Terminal numbers are on the switch.

• Standard Hardware: AT503 Face Hex Nut, AT506 Locking Ring, AT508 Lockwasher, AT527M Backup Hex Nut. See [Accessories & Hardware Index](#) for details.



S42T

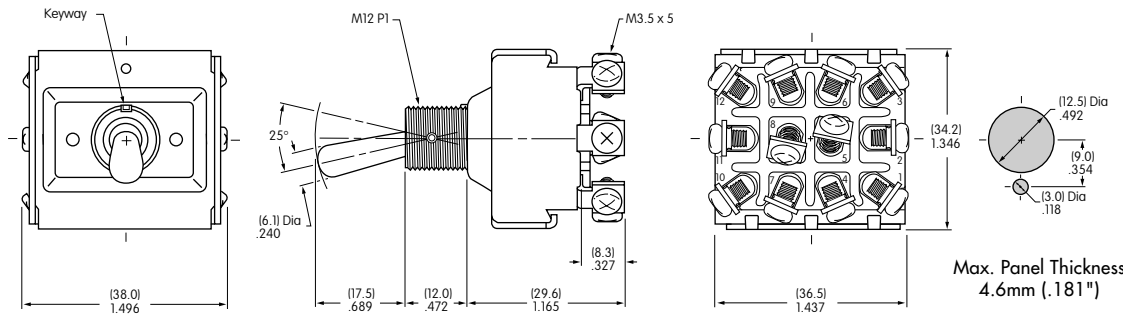

S41T model does not have terminals 2, 5, 8, & 11.





# Series S

## Medium/High Capacity Toggle Switches

### THREE POLE WITH QUICK CONNECT

Model	Approvals	Pole & Throw	Toggle Position/Connected Terminals						Electrical Capacity				$\alpha$ = Angle of Throw
			Down 	Center 	Up 	Resistive			Inductive				
						AC 125V	AC 250V	DC 30V	AC 125V PF 0.6				
S31F	—	3PST	ON	1-3 4-6 7-9	NONE	OFF	—	18A	9A	20A	10A	25°	
S32F	—	3PDT	ON	2-3 5-6 8-9	NONE	ON	2-1 5-4 8-7	18A	9A	20A	10A	25°	
S33F	—	3PDT	ON	2-3 5-6 8-9	OFF	ON	2-1 5-4 8-7	18A	9A	20A	10A	30°	

**Throw & Schematics:** 3PST INTERNAL CONNECTION (COM)

Note: Terminal numbers are on the switch.

• Standard Hardware: AT503 Face Hex Nut, AT506 Locking Ring, AT508 Lockwasher, AT527M Backup Hex Nut. See [Accessories & Hardware Index](#) for details.



S32F

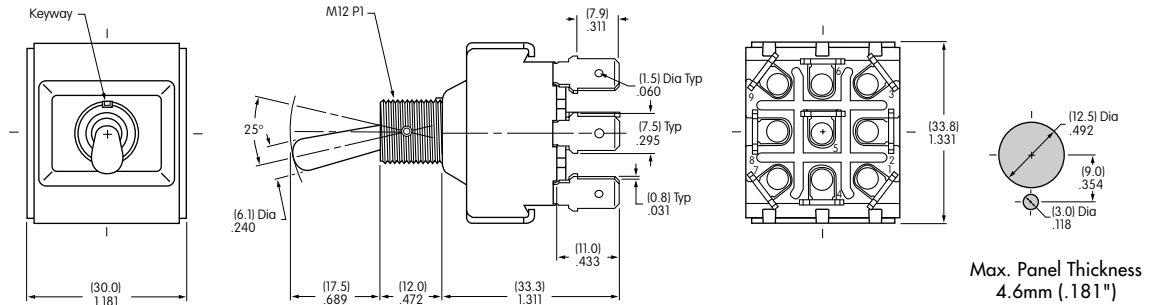

S31F model does not have terminals 2, 5, & 8.

### FOUR POLE WITH QUICK CONNECT

Model	Approvals	Pole & Throw	Toggle Position/Connected Terminals						Electrical Capacity				$\alpha$ = Angle of Throw
			Down 	Center 	Up 	Resistive			Inductive				
						AC 125V	AC 250V	DC 30V	AC 125V PF 0.6				
S41F		4PST	ON	1-3 4-6 7-9 10-12	NONE	OFF	—	18A	9A	20A	10A	25°	
S42F		4PDT	ON	2-3 5-6 8-9 11-12	NONE	ON	2-1 5-4 8-7 11-10	18A	9A	20A	10A	25°	
S43F		4PDT	ON	2-3 5-6 8-9 11-12	OFF	ON	2-1 5-4 8-7 11-10	18A	9A	20A	10A	30°	

**Throw & Schematics:** 4PST INTERNAL CONNECTION (COM)

Note: Terminal numbers are on the switch.

• Standard Hardware: AT503 Face Hex Nut, AT506 Locking Ring, AT508 Lockwasher, AT527M Backup Hex Nut. See [Accessories & Hardware Index](#) for details.



S42F

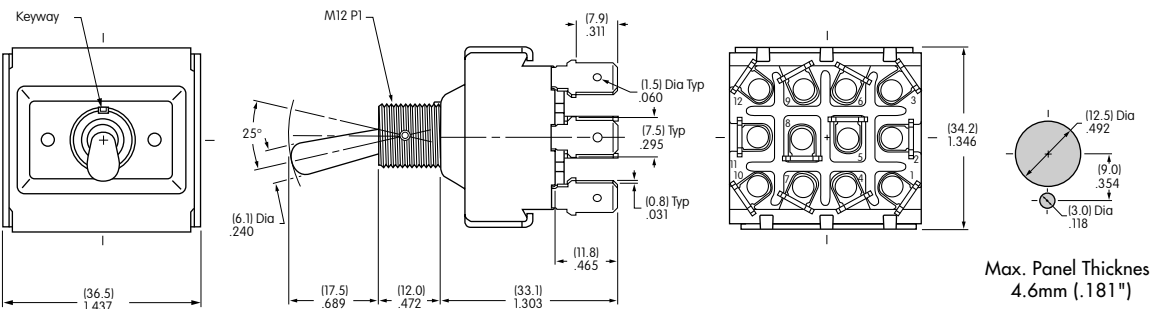

S41F model does not have terminals 2, 5, 8, & 11.



## GENERAL SPECIFICATIONS FOR S421 ~ S429

### Electrical Capacity (Resistive & Inductive Load)

**Power Level:** Shown in the following tables

### Other Ratings

<b>Contact Resistance:</b>	10 milliohms maximum
<b>Insulation Resistance:</b>	1,000 megohms minimum @ 500V DC
<b>Dielectric Strength:</b>	2,000V AC minimum
<b>Mechanical Life:</b>	50,000 operations minimum for all other models
<b>Electrical Life:</b>	15,000 operations minimum; 25,000 operations minimum for all others
<b>Angle of Throw (<math>\alpha</math>):</b>	Shown in tables on following pages

### Materials & Finishes

<b>Toggle:</b>	Brass with chrome plating
<b>Bushing:</b>	Brass with chrome plating
<b>Case:</b>	Phenolic resin
<b>Case Cover:</b>	Steel with zinc plating
<b>Movable Contactor:</b>	Copper with silver plating
<b>Movable Contacts:</b>	Silver alloy capped on copper with silver plating
<b>Stationary Contacts:</b>	Silver alloy capped on copper with silver plating
<b>Terminals:</b>	Brass with silver plating

### Environmental Data

**Operating Temp Range:** -10°C through +70°C (+14°F through +158°F)

### Installation

<b>Mounting Torque:</b>	30 kgf/cm (26 lb/in) for double nut; 15 kgf/cm (13 lb/in) for single nut
<b>Maximum Panel Thickness:</b>	Shown beneath panel cutout in switch dimension drawings
<b>Soldering Time &amp; Temperature:</b>	3 seconds @ 350°C or 5 seconds @ 270°C









# Series S

## Medium/High Capacity Toggle Switches

### DOUBLE POLE WITH SOLDER LUG

Model	Approvals	Pole & Throw	Toggle Position/Connected Terminals						Electrical Capacity				$\alpha$ = Angle of Throw
			Down 	Center 	Up 	Resistive		Inductive		Motor Load AC 125V			
						AC 125V	AC 250V	PF 0.75-0.8 AC 125V	AC 250V				
S421	—	DPST	ON	1-3 4-6	NONE	OFF	—	25A	25A	25A	25A	750W	24°
S422	—	DPDT	ON	2-3 5-6	NONE	ON	2-1 5-4	25A	25A	25A	25A	750W	24°
S423	—	DPDT	ON	2-3 5-6	OFF	ON	2-1 5-4	25A	25A	25A	25A	750W	28°
S425	—	DPDT	ON	2-3 5-6	NONE	MOM	2-1 5-4	15A	15A	15A	15A	400W	24°
S428	—	DPDT	MOM	2-3 5-6	OFF	MOM	2-1 5-4	15A	15A	15A	15A	400W	24°
S429	—	DPDT	ON	2-3 5-6	OFF	MOM	2-1 5-4	15A	15A	15A	15A	400W	24°

**Throw & Schematics:** DPST  INTERNAL CONNECTION DPDT  Note: Terminal numbers are on the switch.

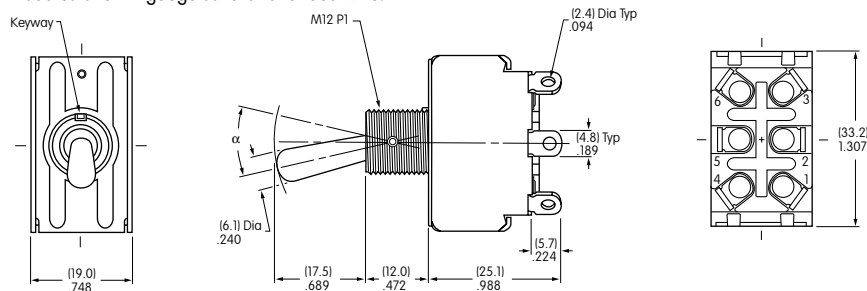

- Standard Hardware: AT503 Face Hex Nut, AT506 Locking Ring, AT508 Lockwasher, AT527M Backup Hex Nut. See [Accessories & Hardware Index](#) for details.
- Solder lug terminal hole accommodates one 12-gauge solid or stranded wire.



Max. Panel Thickness 4.7mm (.185")

S421 model does not have terminals 2 & 5.

### DOUBLE POLE WITH SCREW LUG

Model	Approvals	Pole & Throw	Toggle Position/Connected Terminals						Electrical Capacity				$\alpha$ = Angle of Throw
			Down 	Center 	Up 	Resistive		Inductive		Motor Load AC 125V			
						AC 125V	AC 250V	PF 0.75-0.8 AC 125V	AC 250V				
S421T	—	DPST	ON	1-3 4-6	NONE	OFF	—	20A	20A	20A	20A	750W	24°
S422T	—	DPDT	ON	2-3 5-6	NONE	ON	2-1 5-4	20A	20A	20A	20A	750W	24°
S423T	—	DPDT	ON	2-3 5-6	OFF	ON	2-1 5-4	20A	20A	20A	20A	750W	28°
S425T	—	DPDT	ON	2-3 5-6	NONE	MOM	2-1 5-4	15A	15A	15A	15A	400W	24°
S428T	—	DPDT	MOM	2-3 5-6	OFF	MOM	2-1 5-4	15A	15A	15A	15A	400W	24°
S429T	—	DPDT	ON	2-3 5-6	OFF	MOM	2-1 5-4	15A	15A	15A	15A	400W	24°

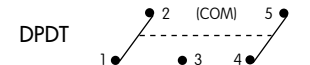
**Throw & Schematics:** DPST  INTERNAL CONNECTION DPDT  Note: Terminal numbers are on the switch.

- Standard Hardware: AT503 Face Hex Nut, AT506 Locking Ring, AT508 Lockwasher, AT527M Backup Hex Nut. See [Accessories & Hardware Index](#) for details.

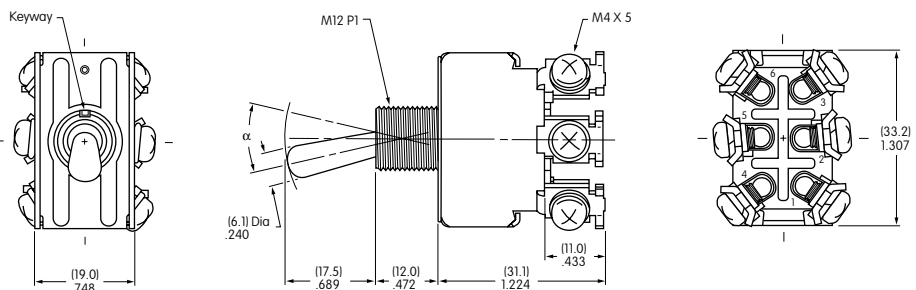

Max. Panel Thickness 4.7mm (.185")

S421T model does not have terminals 2 & 5.