



GENERAL SPECIFICATIONS FOR S1 ~ S29

Electrical Capacity (Resistive & Inductive Load)

Power Level: Shown in the following tables

Other Ratings

Contact Resistance:	10 milliohms maximum
Insulation Resistance:	1,000 megohms minimum @ 500V DC
Dielectric Strength:	2,000V AC minimum
Mechanical Life:	30,000 operations minimum for S5AW, S8AW, S9AW, S25AW, S28AW, S29AW 50,000 operations minimum for all other models
Electrical Life:	15,000 operations minimum for S331s; 25,000 operations minimum for all others; 10,000 operations minimum with lamp load
Angle of Throw (α):	Shown in tables on following pages

Materials & Finishes

Toggle:	Brass with chrome plating
Bushing:	Brass with chrome plating
Case:	Phenolic resin
Case Cover:	Steel with zinc plating
Movable Contactor:	Copper with silver plating
Movable Contacts:	Silver alloy capped on copper with silver plating
Stationary Contacts:	Silver alloy capped on copper with silver plating
Terminals:	Brass with silver plating

Environmental Data

Operating Temp Range:	-30°C through +70°C (-22°F through +158°F) for Splashproof models; -10°C through +70°C (+14°F through +158°F) for all other models
Sealing:	Splashproof & lever lock models meet IP67 standard

Installation

Mounting Torque:	30 kg/cm (26 lb/in) for double nut; 15 kg/cm (13 lb/in) for single nut
Maximum Panel Thickness:	Shown beneath panel cutout in switch dimension drawings
Soldering Time & Temperature:	3 seconds @ 350°C or 5 seconds @ 270°C

Standards & Certifications









UL Recognized:	Designated with UL recognized symbol beside part numbers on following pages See Supplement Index to find UL rating details. UL File No. E44145 Add "/U" to end of part number to order UL mark on switch.
CSA Certified:	Designated with CSA certified symbol beside part numbers on following pages See Supplement Index to find CSA rating details. File No. LR23535 Add "/C" to end of part number to order CSA mark on switch.



Series S

Medium Capacity Toggle Switches

SINGLE POLE WITH SOLDER LUG

Model	Approvals	Pole & Throw	Toggle Position/Connected Terminals			Electrical Capacity				Angle of Throw
			Down 	Center 	Up 	Resistive			Inductive	
						AC 125V	AC 250V	DC 30V	AC 125V PF 0.6	
S1A	 	SPST	ON 1-3	NONE	OFF —	15A	6A	20A	8A	25°
S2A	 	SPDT	ON 2-3	NONE	ON 2-1	15A	6A	20A	8A	25°
S3A	 	SPDT	ON 2-3	OFF	ON 2-1	15A	6A	20A	8A	25°

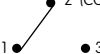
Throw & Schematics: SPST  INTERNAL CONNECTION SPDT  2 (COM)

Note: Terminal numbers are on the switch.



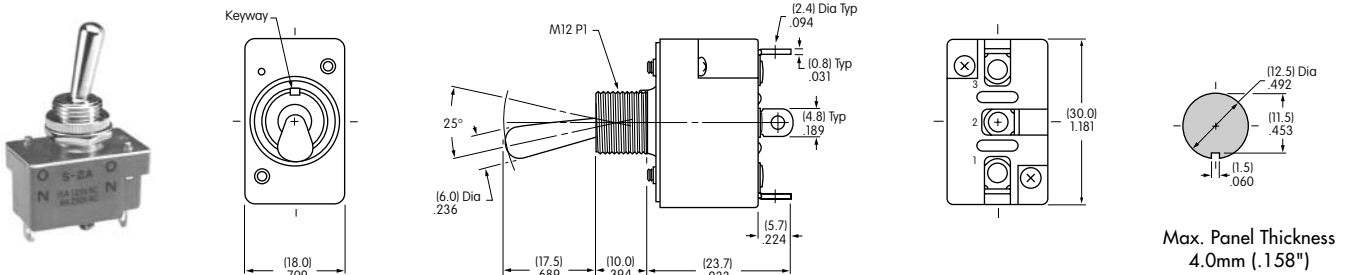



- Standard Hardware: AT504M Knurled Nut, AT508 Lockwasher, AT527M Backup Hex Nut. See [Accessories & Hardware Index](#) for details.
- Solder lug terminal hole accommodates one 12-gauge solid or stranded wire.





S2A

S1A does not have terminal 2.

DOUBLE POLE WITH SOLDER LUG

Model	Approvals	Pole & Throw	Toggle Position/Connected Terminals			Electrical Capacity				α = Angle of Throw
			Down 	Center 	Up 	Resistive			Inductive	
						AC 125V	AC 250V	DC 30V	AC 125V PF 0.6	
S21A	— —	DPST	ON 1-3 4-6	NONE	OFF —	15A	15A	15A	8A	21°
S6A	 	DPDT	ON 2-3 5-6	NONE	ON 2-1 5-4	20A	10A	20A	8A	21°
S7A	— 	DPDT	ON 2-3 5-6	OFF	ON 2-1 5-4	20A	10A	20A	8A	28°

Throw & Schematics: DPST  INTERNAL CONNECTION DPDT  2 (COM)

Note: Terminal numbers are on the switch.

- Standard Hardware: AT504M Knurled Nut, AT508 Lockwasher, AT527M Backup Hex Nut. See [Accessories & Hardware Index](#) for details.
- Solder lug terminal hole accommodates one 12-gauge solid or stranded wire.

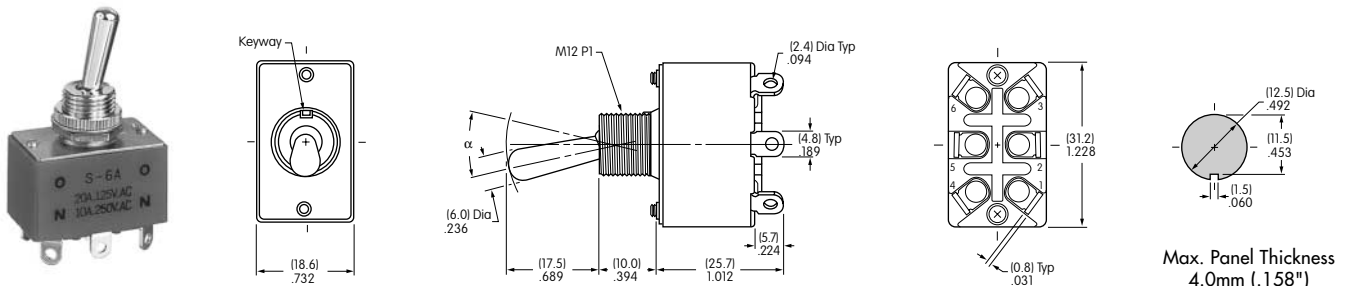

S6A

S21A does not have terminals 2 & 5.



Series S

Medium Capacity Toggle Switches

SINGLE POLE WITH QUICK CONNECT

Model	Approvals	Pole & Throw	Toggle Position/Connected Terminals			Electrical Capacity				Angle of Throw
			Down 	Center 	Up 	Resistive			Inductive	
						AC 125V	AC 250V	DC 30V	AC 125V PF 0.6	
S1F	— —	SPST	ON 1-3	NONE	OFF —	15A	6A	20A	8A	25°
S2F	— —	SPDT	ON 2-3	NONE	ON 2-1	15A	6A	20A	8A	25°
S3F	— —	SPDT	ON 2-3	OFF	ON 2-1	15A	6A	20A	8A	25°

Throw & Schematics: SPST INTERNAL CONNECTION SPDT

Note: Terminal numbers are on the switch.

• Standard Hardware: AT503 Face Hex Nut, AT508 Lockwasher, AT527M Backup Hex Nut. See [Accessories & Hardware Index](#) for details.

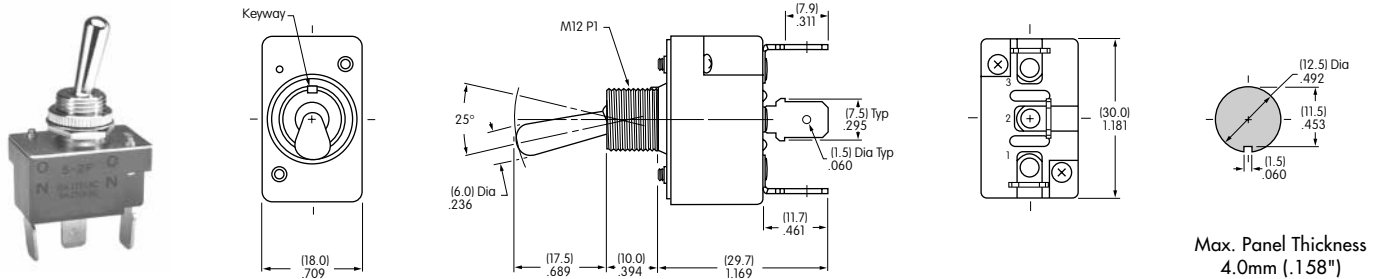

S2F

S1F does not have terminal 2.

DOUBLE POLE WITH QUICK CONNECT

Model	Approvals	Pole	Toggle Position/Connected Terminals			Electrical Capacity				α = Angle of Throw
			Down 	Center 	Up 	Resistive			Inductive	
						AC 125V	AC 250V	DC 30V	AC 125V PF 0.6	
S21F	— —	DPST	ON 1-3 4-6	NONE	OFF —	15A	15A	15A	8A	21°
S6F	— —	DPDT	ON 2-3 5-6	NONE	ON 2-1 5-4	20A	10A	20A	8A	21°
S7F	— —	DPDT	ON 2-3 5-6	OFF	ON 2-1 5-4	20A	10A	20A	8A	28°

Throw & Schematics: DPST INTERNAL CONNECTION DPDT

Note: Terminal numbers are on the switch.

• Standard Hardware: AT503 Face Hex Nut, AT508 Lockwasher, AT527M Backup Hex Nut. See [Accessories & Hardware Index](#) for details.

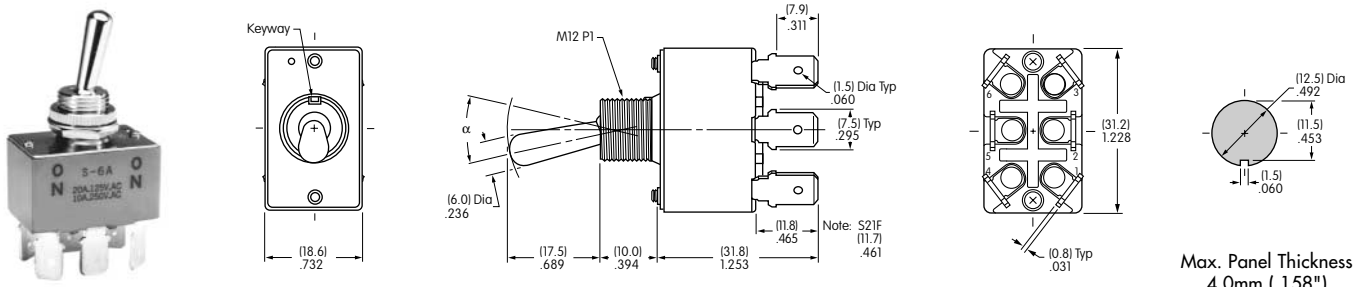

S6F

S21F does not have terminals 2 & 5.



Series S

Medium Capacity Toggle Switches

SINGLE POLE WITH PANEL SEAL

Model	Approvals	Pole & Throw	Toggle Position/Connected Terminals				Electrical Capacity				α = Angle of Throw	
			Down 	Center 	Up 	Resistive			Inductive			
						AC 125V	AC 250V	DC 30V	AC 125V			
S1AW	— —	SPST	ON	1-3	NONE	OFF	—	15A	6A	20A	200W	24°
S2AW	— —	SPDT	ON	2-3	NONE	ON	2-1	15A	6A	20A	200W	24°
S3AW	— —	SPDT	ON	2-3	OFF	ON	2-1	15A	6A	20A	200W	28°
S5AW	— —	SPDT	ON	2-3	NONE	MOM	2-1	15A	6A	20A	200W	20°
S8AW	— —	SPDT	MOM	2-3	OFF	MOM	2-1	15A	6A	20A	200W	24°
S9AW	— —	SPDT	ON	2-3	OFF	MOM	2-1	15A	6A	20A	200W	24°

Throw & Schematics: SPST INTERNAL CONNECTION SPDT

Note: Terminal numbers are on the switch.

- Standard Hardware: AT503 Face Hex Nut, AT508 Lockwasher, AT537 O-ring. See [Accessories & Hardware Index](#) for details.
- Solder lug terminal hole accommodates one 12-gauge solid or stranded wire.

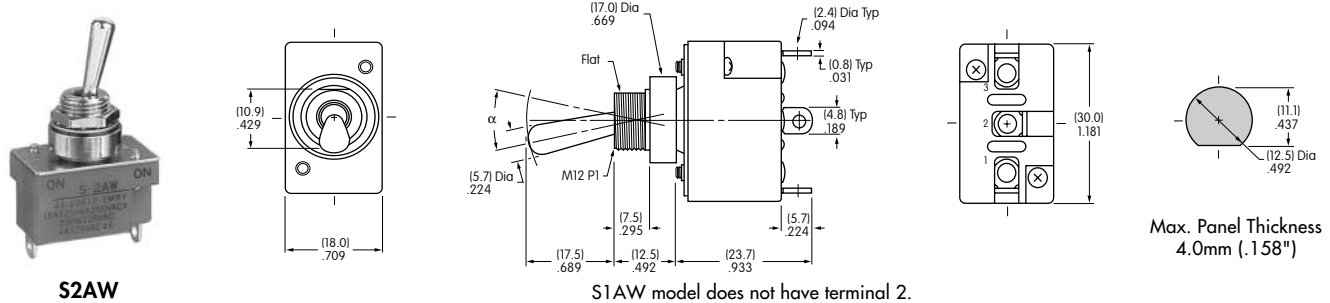

DOUBLE POLE WITH PANEL SEAL

Model	Approvals	Pole & Throw	Toggle Position/Connected Terminals				Electrical Capacity				α = Angle of Throw	
			Down 	Center 	Up 	Resistive			Inductive			
						AC 125V	AC 250V	DC 30V	AC 125V			
S21AW	— —	DPST	ON	1-3 4-6	NONE	OFF	—	15A	15A	15A	200W	22°
S6AW	— —	DPDT	ON	2-3 5-6	NONE	ON	2-1 5-4	20A	10A	20A	—	22°
S7AW	— —	DPDT	ON	2-3 5-6	OFF	ON	2-1 5-4	20A	10A	20A	—	28°
S25AW	— —	DPDT	ON	2-3 5-6	NONE	MOM	2-1 5-4	15A	6A	20A	—	20°
S28AW	— —	DPDT	MOM	2-3 5-6	OFF	MOM	2-1 5-4	15A	6A	20A	—	22°
S29AW	— —	DPDT	ON	2-3 5-6	OFF	MOM	2-1 5-4	15A	6A	20A	—	22°

Throw & Schematics: DPST INTERNAL CONNECTION DPDT

Note: Terminal numbers are on the switch.

- Standard Hardware: AT503 Face Hex Nut, AT508 Lockwasher, AT537 O-ring. See [Accessories & Hardware Index](#) for details.
- Solder lug terminal hole accommodates one 12-gauge solid or stranded wire.

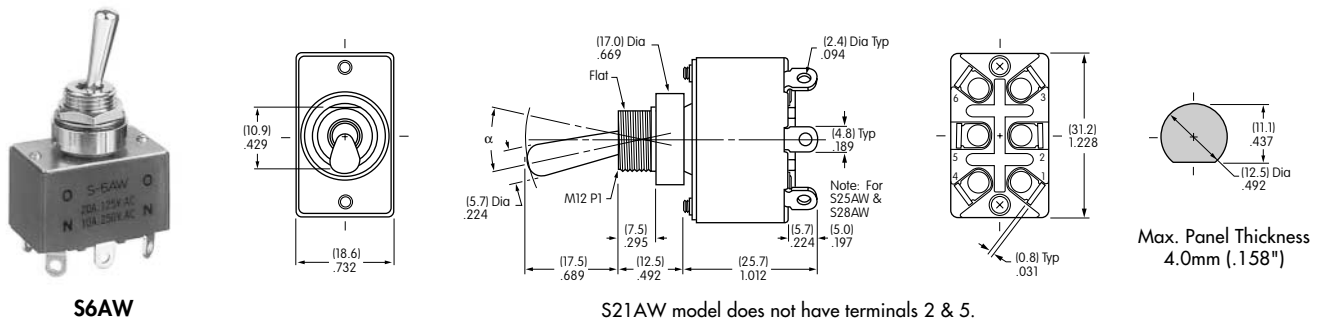



Series S

Medium Capacity Toggle Switches

SINGLE POLE WITH LOCKING LEVER & PANEL SEAL

Model	Approvals	Pole & Throw	Toggle Position/Connected Terminals			Electrical Capacity				α = Angle of Throw
			Down 	Center 	Up 	Resistive			Inductive	
						AC 125V	AC 250V	DC 30V	AC 125V	
S1AL	— —	SPST	ON 1-3	NONE	OFF —	15A	6A	20A	8A	24°
S2AL	— —	SPDT	ON 2-3	NONE	ON 2-1	15A	6A	20A	8A	24°
S3AL	— —	SPDT	ON 2-3	OFF	ON 2-1	15A	6A	20A	8A	28°

Throw & Schematics: SPST INTERNAL CONNECTION SPDT

Note: Terminal numbers are on the switch.

- Standard Hardware: AT503 Face Hex Nut, AT508 Lockwasher, AT537 O-ring. See [Accessories & Hardware Index](#) for details.
- Solder lug terminal hole accommodates one 12-gauge solid or stranded wire.



S2AL

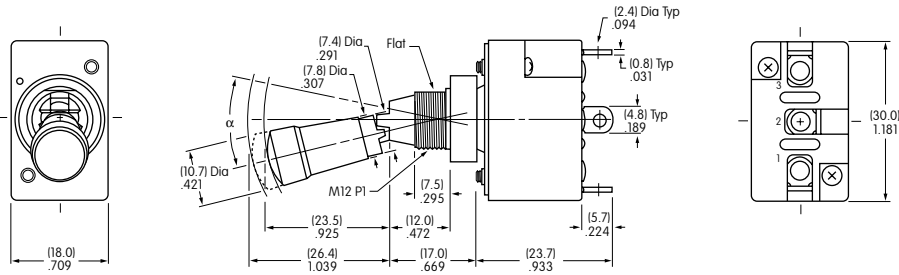

S1AL model does not have terminal 2.

Max. Panel Thickness
4.0mm (.158")

DOUBLE POLE WITH LOCKING LEVER & PANEL SEAL

Model	Approvals	Pole & Throw	Toggle Position/Connected Terminals			Electrical Capacity				α = Angle of Throw
			Down 	Center 	Up 	Resistive			Inductive	
						AC 125V	AC 250V	DC 30V	AC 125V	
S21AL	— —	DPST	ON 1-3 4-6	NONE	OFF —	15A	15A	15A	8A	22°
S6AL	— —	DPDT	ON 2-3 5-6	NONE	ON 2-1 5-4	20A	10A	20A	8A	22°
S7AL	— —	DPDT	ON 2-3 5-6	OFF	ON 2-1 5-4	20A	10A	20A	8A	28°

Throw & Schematics: DPST INTERNAL CONNECTION DPDT

Note: Terminal numbers are on the switch.

- Standard Hardware: AT503 Face Hex Nut, AT508 Lockwasher, AT537 O-ring. See [Accessories & Hardware Index](#) for details.
- Solder lug terminal hole accommodates one 12-gauge solid or stranded wire.



S6AL

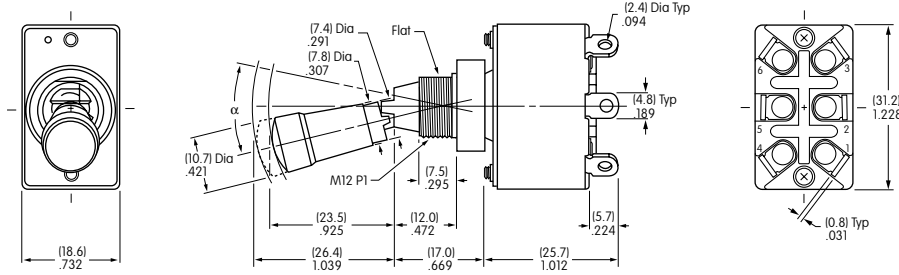

S21AL model does not have terminals 2 & 5.

Max. Panel Thickness
4.0mm (.158")